



# Clamp-On Flow Meter

FD-R Series



All You Need To Do Is  
**Clamp-On**

Display  
Unit  
FI-1000



FD-R Series

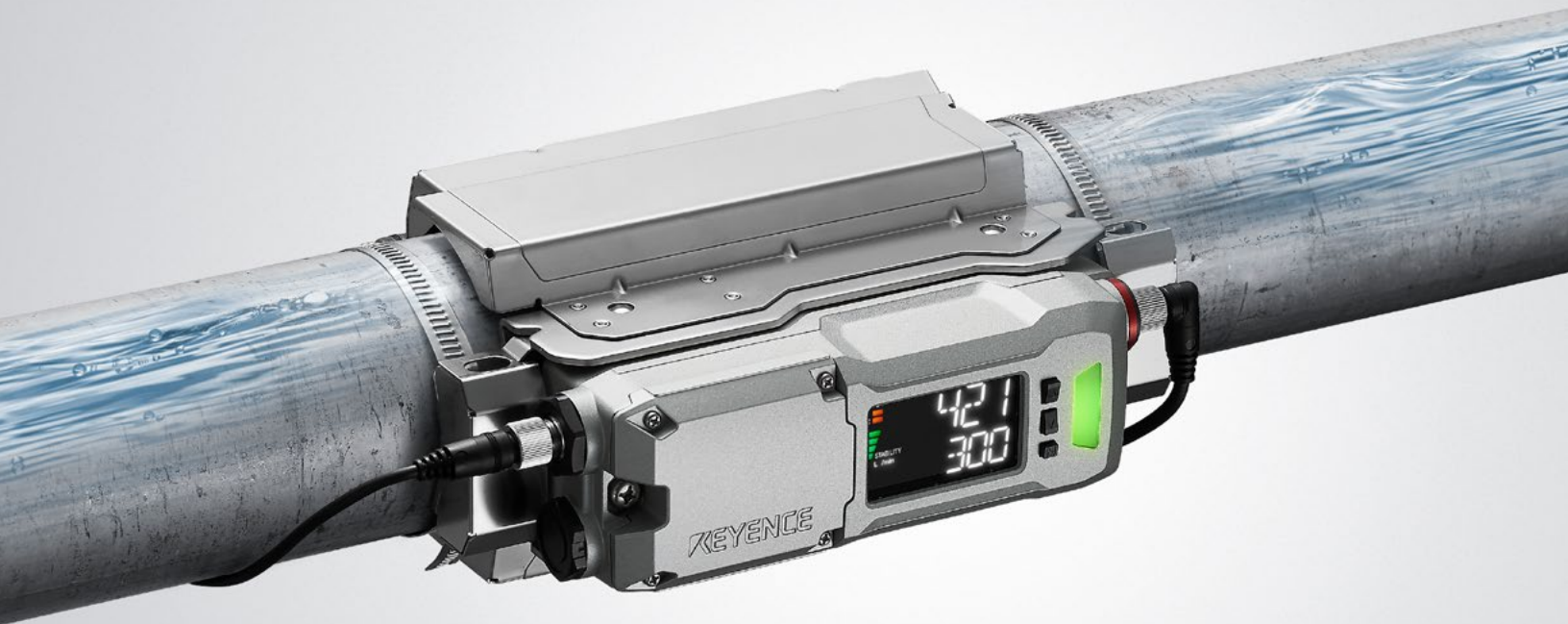
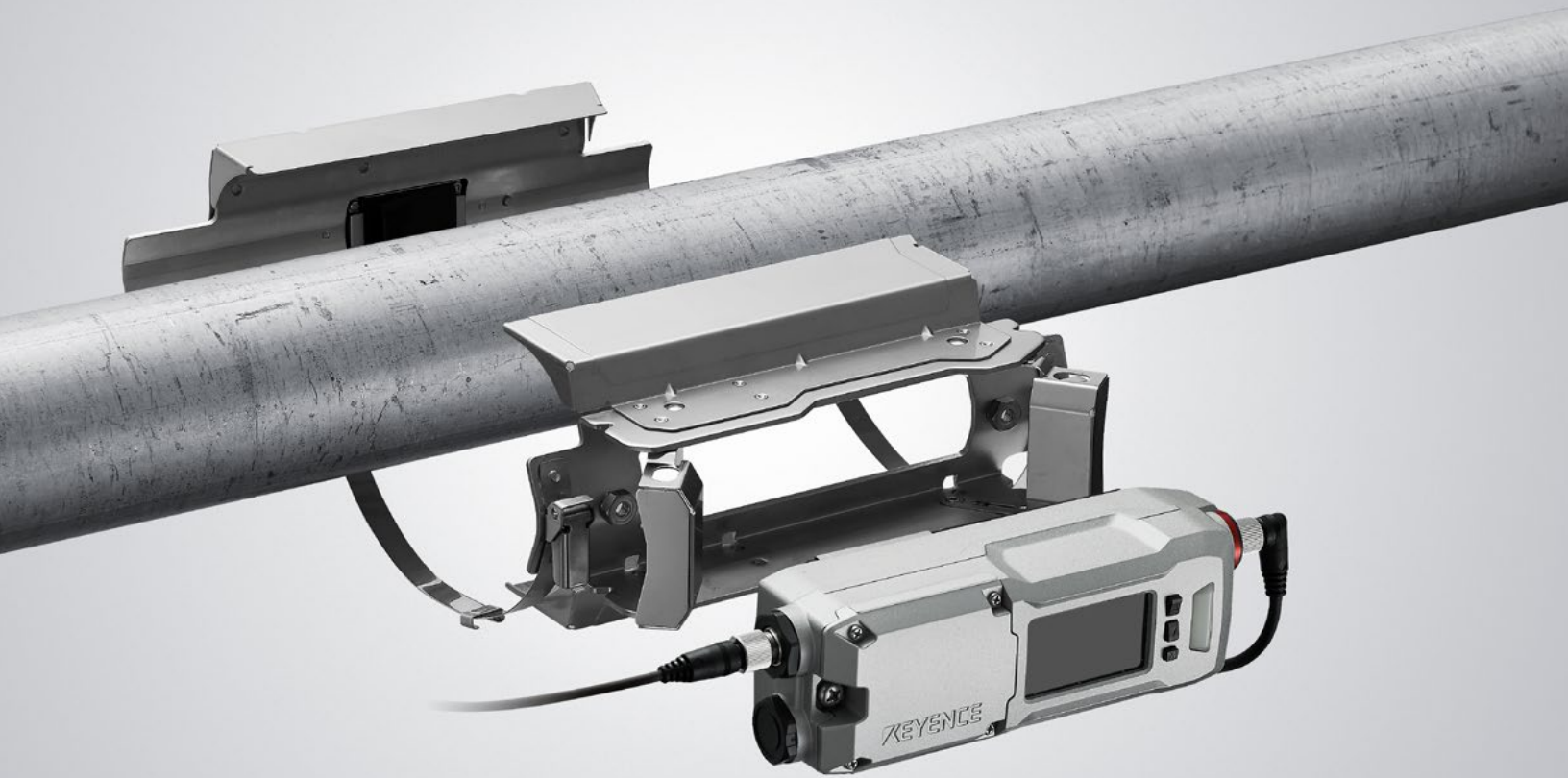

# Clamp-On Flow Meter

## FD-R Series

### INNOVATIVE INSTALLATION

- Mounted securely in minutes
- No pipe modifications necessary

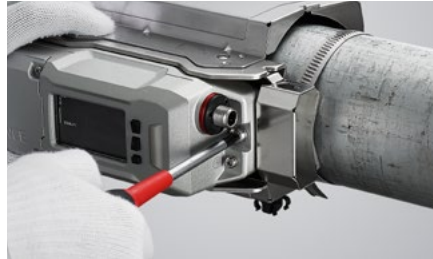

### LIMITLESS USES

- Compatible with various pipes and liquids
- Versatile features for any situation



### LASTING RELIABILITY

- Consistently stable detection
- Completely non-invasive setup



FD-R50



FD-R80



FD-R125



FD-R200



# INNOVATIVE INSTALLATION

## ■ Mounted in Minutes

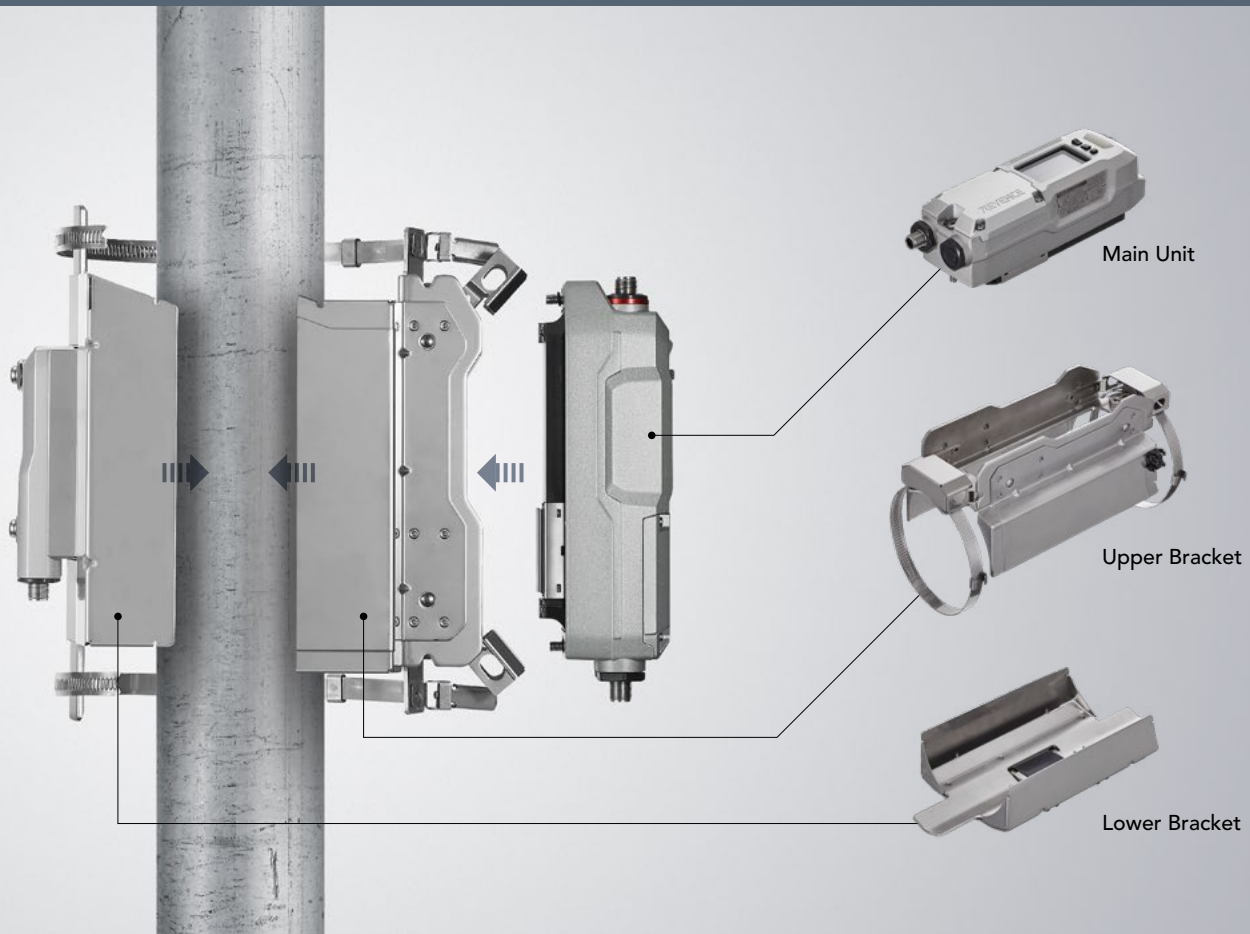

### Three Pieces and as few as Four Screws

All models feature a simple three piece design, consisting of the lower bracket, upper bracket, and main unit. These pieces are quickly and easily secured to the pipe with either 4 or 6 screws

### Repeatable Setup

Regardless of who installs the unit, the results will always be repeatable. The intuitive bracket design removes the guess work from installation and ensures consistent mounting by anyone.

### Rugged Yet Lightweight Design

The FD-R brackets are expertly designed to be durable enough to withstand the rigors of the factory environment, yet light enough to be installed by just a single individual.

# ■ Benefits of the Clamp-On Design

## No Pipe Modification Necessary

The difficulties commonly associated with installing a new flow meter are eliminated by simply Clamping-On. This design eliminates the need to cut pipes, thread pipes, shut down machines, contract plumbers/engineers, weld segments, and much more.

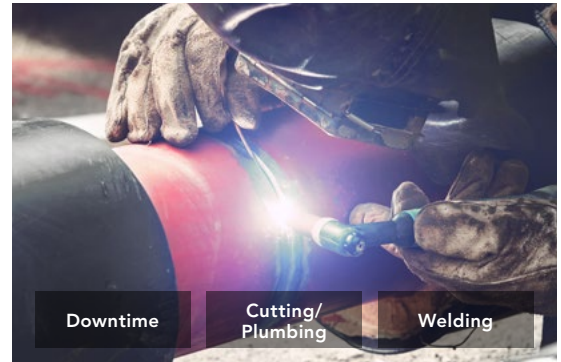

## No Special Tools Needed

All it takes is a single Phillips-head screwdriver to install the FD-R securely to an existing pipe. This ensures that proper installation can be achieved by any member of the team without the need for special tools or specialized knowledge.



## Greatly Reduced Costs

The elimination of the time and money associated with pipe modification, machine downtime, and additional component purchasing, allows the FD-R to be utilized with all machines for continuous process improvement. Justification has never been easier.

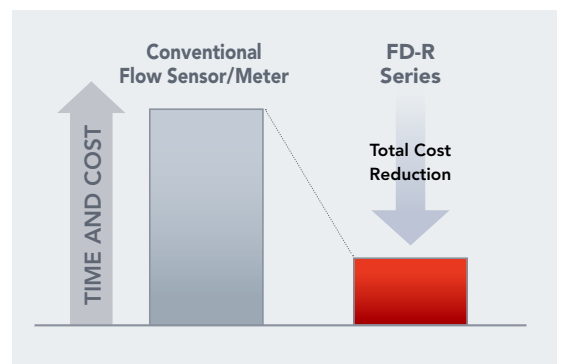

# LIMITLESS USES

## ■ Ideal in Nearly any Situation



1 1/2" to 2"



2 1/2" to 3"



4" to 5"



6" to 8"

## ■ Detectable Fluids



Water



DI Water



Oil



Chemicals



Product

## ■ Compatible Pipe Materials



Stainless Steel



Iron



Copper



PVC



Resin

## ■ Available Sizes

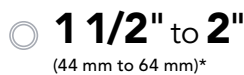

1 1/2" to 2"  
(44 mm to 64 mm)\*



2 1/2" to 3"  
(64 mm to 100 mm)\*

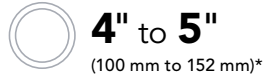

4" to 5"  
(100 mm to 152 mm)\*



6" to 8"  
(152 mm to 220 mm)\*

\*Pipe Outer Diameter

# Versatile Features for all Applications

## Impressive Accuracy

The measurement accuracy specifications associated with the FD-R allow it to be used for both general sensing applications and situations requiring more precise monitoring. This makes it easier than ever before to properly detect flow.

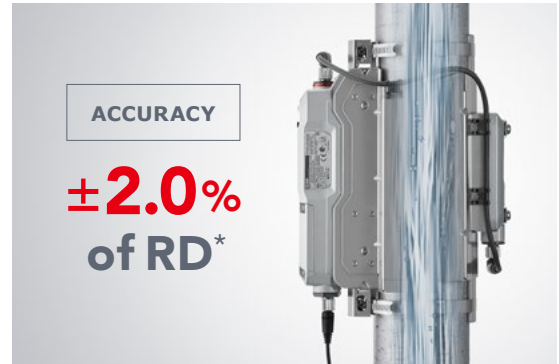

\*Please see the specifications.

## Superior Environmental Resistance

IP65/67

IP69K

NEMA 4X\*

Whether being used indoors or outdoors, in the cleanest or the dirtiest environments, the FD-R Series is designed to last. The ratings above ensure proper operation regardless of contact with liquids or dust in the environment.

\*Enclosure Type 4X (NEMA 250)



## Integrated Temperature Monitoring

Temperature and flow monitoring can now be achieved simultaneously with just one device. Quickly and easily monitor a range of temperatures using the Integrated Temperature Monitoring function.

Accuracy:  $\pm 3^{\circ}\text{C}$   $\pm 5.4^{\circ}\text{F}$ \*

\*-20 to 50°C -4 to 122°F, ambient temperature is 25°C 77°F



# LASTING RELIABILITY

## ■ Dependable Detection That Lasts



### High Powered Signal

The FD-R utilizes an ultrasonic signal 20X stronger than conventional models.

### Automatic Build-Up Resistance

The FD-R automatically increases its signal strength to blast through harsh build-up for lasting detection.

Standard Power  
(Clean Pipe)



Increased Power  
(Pipe With Build-Up)



The already powerful signal will automatically increase its strength when build-up is detected

## ■ Downtime Eliminated

### Completely Non-Invasive Setup

The design of the FD-R Series ensures that there will be zero impact on the flow system. Unlike conventional models (mechanical, thermal, etc.), this removes concerns associated with pressure loss, contamination, flow obstructions, and/or liquid leakage.

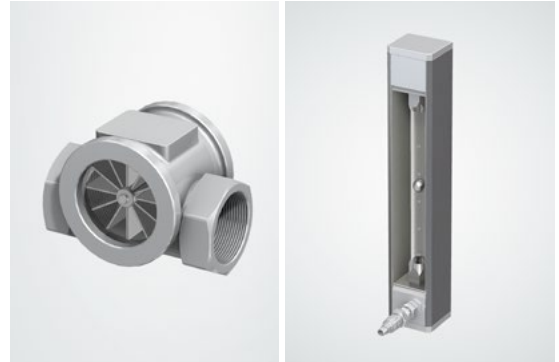

### No Adjustments Necessary

The robust mounting provided by the FD-R brackets eliminates the need for any adjustments after the unit has been installed. Unlike conventional ultrasonic flow meters that stop working due to physical contact or build-up, the FD-R Series provides consistently stable detection that lasts.



### Built-In Predictive Maintenance

Using Conditional Monitoring, it is possible to easily identify potential flow concerns early and prevent them from causing downtime. This is possible using multiple outputs and the easy to read display, which can show flow as a percentage of an optimum value.



# ADDITIONAL FUNCTIONALITY

## Detection Modes



### Typical flow control

#### [STD] Mode

The output turns ON when the instantaneous flow rate is above or below a user defined threshold.

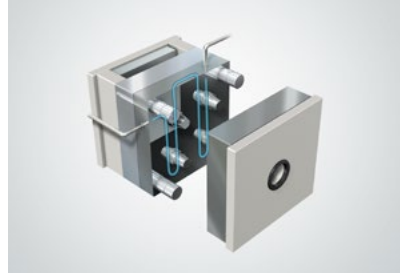

### Flow range control

#### [AREA] Mode

The output turns ON when the instantaneous flow rate falls outside or inside a user defined window.



### Totalizing flow

#### [TOTAL] Mode

The output turns ON after a user defined amount of liquid has passed.

## Available I/O

### Control Outputs

PNP/NPN  
Single/Dual  
Flow & Temperature

### Analog Outputs

4 to 20 mA  
0 to 20 mA  
Single/Dual  
Flow & Temperature

### External Input

Reset  
Flow Rate Zero Shift  
Origin Adjustment

### IO-Link

Instantaneous Flow  
Total Accumulated Flow  
Settings Information

## Easily Reviewable Data

Quickly check historic flow and temperature data through the display on the FD-R Series using its built-in data recorder.

### Types of Data

- Instantaneous flow rate
- Temperature
- Total accumulated flow
- Event information

### Frequency of Recording

- Once every 5 minutes\*
- Once per day
- Once per week
- Once per month

\* Instantaneous flow rate and temperature only



## Simulation Mode



Conveniently check that the outputs are connected properly without needing to change the actual flow rate or temperature.

## Quick Setting Code



All it takes is a 10 digit code to seamlessly transfer settings from one unit to any number of additional units.

## Highly Visible Indicator

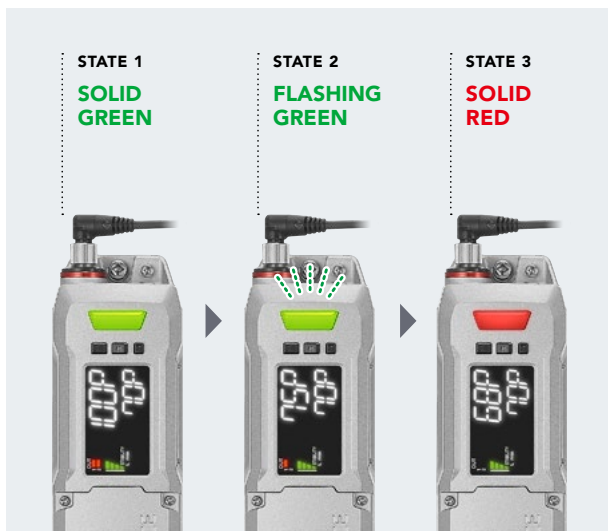

The highly visible indicator and display provide clear indications of the current situation for hassle-free troubleshooting.

## Supporting Various Communication Options

### Ethernet Module MP-FEN1

► See page 17 for details

[Supported protocols]

- EtherNet/IP®
- PROFINET
- Modbus/TCP
- MC protocol/SLMP



### Network Communication Module NQ Series

#### IO-Link

[Supported protocols]

- EtherNet/IP®
- PROFINET
- Modbus/TCP
- CC-Link
- EtherCAT®



Data collection needs are increasingly growing. Various communication options are available by connecting to the Ethernet module MP-FEN1 and NQ Series network communication modules.

\* EtherCAT® is registered trademark and patented technology, licensed by Beckhoff Automation GmbH, Germany.

**Furnace/Annealing Machine**

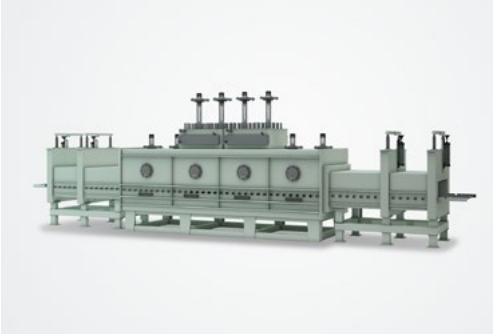

**Processing Machine**



**Die Casting Machine**



**VARIOUS APPLICATIONS**

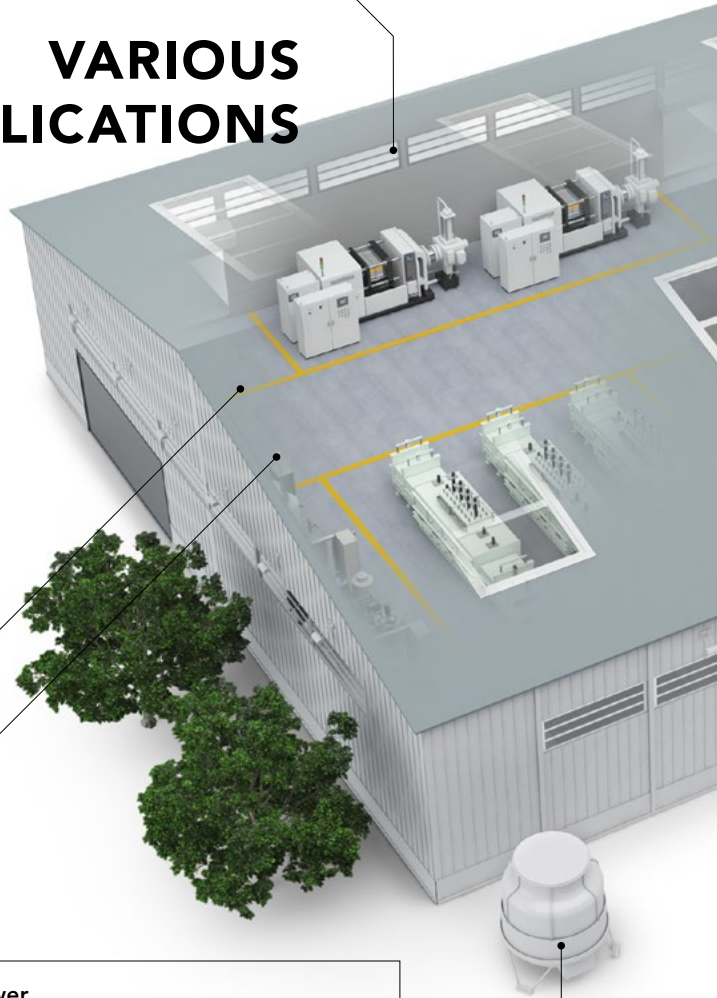

**Stirrer**



**Chiller**



**Cooling Tower**



**Two-Solution Mixer**



**Sterilization Machine**



**Plating Machine**



**Concrete Mixer**



**Waste Water System**



# COMPLETE PROCESS MONITORING

Extend Beyond Flow Sensing To Understand the Full System

Look at more than  
just flow!

Concentration    Temperature    Level

## Introducing Complete Process Solutions

Monitor and manage multiple variables all through one centralized device.

The FD-R Series can be connected to the FI-1000 Series display unit with ease. The display unit can then be connected to up to two additional devices to pull in process data related to temperature, level, and/or concentration. This helps provide a complete picture of machine performance.



The FI-1000 display can connect to the FD-R Series as well as two additional devices

FI-1000 Display Unit **NEW**



Multi-Port



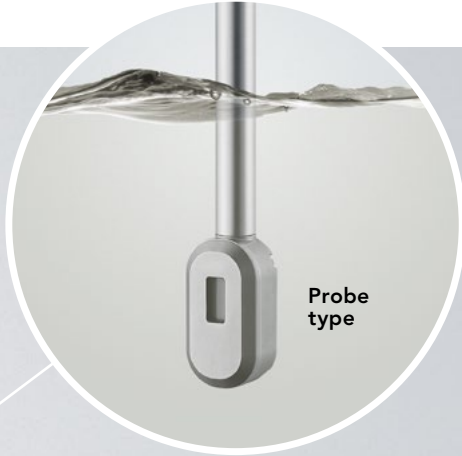

Probe type

## + Concentration

Digital Refractometer  
FI-C Series NEW

In-Line type



## + Temperature

Temperature Sensor  
FI-T Series NEW



## + Level

Sensing Guide Pulse Level Sensor  
FL Series

# SELECTION GUIDE

## STEP 1 Main Unit Selection

- ① Select the main unit by referencing the size of the pipe the unit will be mounted on.      ② Confirm the rated flow velocity and flow rate ranges are acceptable for the application

Supported pipe size (Outer diameter)	Appearance	Model	Rated flow velocity range	Flow rate range (Typical)	Weight
1 1/2" (40A) (ø44 to ø55 ø1.73" to ø2.17")		<b>FD-R50</b>	0.3 m/s to 5 m/s	36 to 400 L/min 9 to 100 gal/min 2.4 to 24 m³/h	Approx. 2.5 kg 5.51 lb
2" (50A) (ø55 to ø64 ø2.17" to ø2.52")				36 to 600 L/min 9 to 150 gal/min 2.4 to 36 m³/h	
2 1/2" (65A) (ø64 to ø83 ø2.52" to ø3.27")		<b>FD-R80</b>		90 to 1000 L/min 24 to 260 gal/min 5.4 to 60 m³/h	Approx. 3.0 kg 6.61 lb
3" (80A) (ø83 to ø100 ø3.27" to ø3.94")				90 to 1500 L/min 24 to 390 gal/min 5.4 to 90 m³/h	
4" (100A) (ø100 to ø127 ø3.94" to ø5.00")		<b>FD-R125</b>		220 to 2500 L/min 60 to 660 gal/min 12 to 150 m³/h	Approx. 3.3 kg 7.28 lb
5" (125A) (ø127 to ø152 ø5.00" to ø5.98")				220 to 3700 L/min 60 to 990 gal/min 12 to 220 m³/h	
6" (150A) (ø152 to ø191 ø5.98" to ø7.52")		<b>FD-R200</b>		570 to 5500 L/min 150 to 1400 gal/min 36 to 330 m³/h	Approx. 3.5 kg 7.72 lb
8" (200A) (ø191 to ø220 ø7.52" to ø8.66")				570 to 9500 L/min 150 to 2500 gal/min 36 to 570 m³/h	

\*The minimum flow rates (zero cut flow rates) can be changed in the settings.

### When Connecting to the FI-1000 Display Unit

#### Display Unit FI-1000

The FD-R Series can be connected to this separate display, which can also be connected to up to two additional devices. (DC Power Supply Required.)



#### M12 power supply cable

Power supply cable for FI-1000 (M12 6-core loose wire).

#### FD-HCB2

2 m 6.6' PVC

#### FD-HCB10

10 m 32.8' PVC



#### FD-R Series connection cable OP-88671

M12 4 pin on one side (to connect to the FD-R), the other side is a proprietary connector for FI-1000 connection, cable length 2 m 6.6'.



#### FD-R Series connection extension cable

This is a connector cable with M12 4-pin on one side and M12 4-pin on the other side, which can be connected together for up to 20 m with OP-88671 (2 m 6.6').

OP-85503 2 m 6.6' PVC    OP-88075 2 m 6.6' PUR  
OP-85504 5 m 16.4' PVC    OP-88076 5 m 16.4' PUR



#### Separate display unit bracket FD-HB1

This is a bracket for mounting the display unit.



#### Display unit protection cover FD-HP1



## STEP 2 Cable / Cable Gland Selection Necessary parts differ based on supplied power type (AC/DC)

### When supplying DC power to the unit

Select the M12 power supply cable based upon cable length and indoor or outdoor usages

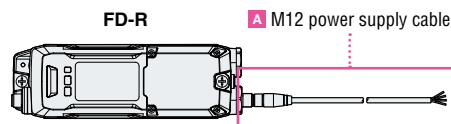

#### A M12 power supply cable

Specifications	Appearance	Model	Length	Material	Weight
Indoor use (standard)		<b>OP-75721</b>	2 m 6.6'	PVC	Approx. 55 g 1.94 oz
		<b>OP-85502</b>	10 m 32.8'	Brass nickel plating	Approx. 220 g 7.76 oz
Indoor use (oil resistant)		<b>OP-87636</b>	2 m 6.6'	PUR	Approx. 75 g 2.65 oz
		<b>OP-87637</b>	10 m 32.8'	Zinc nickel plating	Approx. 260 g 9.17 oz
Outdoor use		<b>OP-88196</b>	10 m 32.8'	PUR SUS316L	Approx. 310 g 10.93 oz

## When supplying AC power to the unit

Detach the covers on the end of the unit and install the cable glands

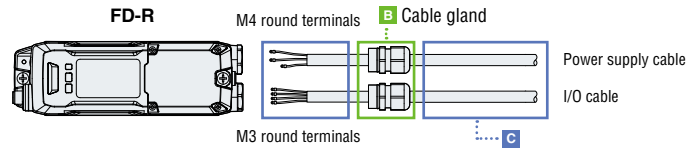

### B Cable gland

Appearance	Material	Compatible cable outer diameter	Number of pieces	Model	Weight
	PA/FKM/EPDM	ø7 to ø12	2 Pieces	<b>OP-88199</b>	Approx. 20 g 0.71 oz 2 pieces

### C Compatible cables and terminals (To be obtained from a 3rd party)

Cable	Type	Finished outer diameter	Nominal cross-sectional area	No. of Wires
	Power supply cable		ø7 to ø12 <sup>*1</sup>	1.75 mm <sup>2</sup> or more <sup>*2</sup>
I/O cable		0.3 mm <sup>2</sup> or more		4 <sup>*3</sup>

Round terminal	Type	Size	Outer size of the round part B	Inside of the round part d
	For power supply cable	M4	ø8.5 or less	ø4.3 or more
For I/O cable	M3	ø5.5 or less	ø3.2 or more	

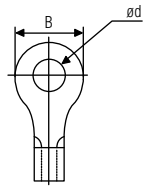

\*1 Finished outer diameter of the cable when using OP-88199

\*2 Please use a two-wire cable with nominal cross area of 0.5 mm<sup>2</sup> or greater to ground the sensor when performing grounding with the protective grounding terminal of the main unit case

\*3 The ch.2 core wire is not required when the ch.2 function is not being used.

\*4 Use cables with heat resistance of 90°C 194°F or higher for the power cable and the I/O cable depending on the temperature conditions. Please see the specifications.

### When using a non-KEYENCE cable gland

The threading on FD-R main unit is G1/2. When using M20 or NPT1/2 cable glands, please use the thread conversion couplings below.

Material	Size conversion	Number of pieces	Model	Weight
Brass nickel plating FKM	G1/2 → M20	1 Piece	<b>OP-88200</b>	Approx. 30 g 1.05 oz
	G1/2 → NPT1/2		<b>OP-88201</b>	Approx. 35 g 1.23 oz

\*If the compatible cable outer diameter or the effective thread depth is not appropriate, the specifications for the enclosure rating cannot be met. Therefore, fluid may enter into the product, leading to electric shock and damage.

## STEP 3 Optional Parts Selection Select parts as needed

### Selection of communication device



Model	Supported protocols
<b>MP-FEN1</b>	EtherNet/IP® PROFINET Modbus/TCP MC protocol/SLMP

### Device configuration



FD-R connection cable (required)  
OP-88762 (2 m 6.6')<sup>\*1</sup>  
M12 male 5-pin - M12 female 4-pin



\*1 Maximum extendable range is 20 m 65.6'.  
Use OP-85503 (2 m 6.6') or similar product for extension of the OP-88762 FD-R connection cable until the desired length is reached.

### MP-FEN1



Power supply cable  
OP-87634 (2 m 6.6'), etc.  
M12 female 4-pin - Loose wires



Ethernet cable  
(OP-88086, etc.)



Various PLCs

Recorder



Type	Appearance	Model	Specifications	Cable length	Weight
FD-R connection cable (with MP-FEN1 connected)		<b>OP-88762</b>	M12 male 5-pin - M12 female 4-pin	2 m 6.6'	Approx. 85 g 2.99 oz
		<b>OP-85503</b>	M12 male 4-pin - M12 female 4-pin	2 m 6.6'	Approx. 70 g 2.46 oz
Power supply cable		<b>OP-87634</b>	M12 female 4-pin - Loose wires	2 m 6.6'	Approx. 160 g 5.64 oz
		<b>OP-87272</b>		5 m 16.4'	Approx. 340 g 11.99 oz
		<b>OP-87635</b>		10 m 32.8'	Approx. 660 g 23.28 oz
Ethernet cable		<b>OP-88086</b>	M12 male - RJ45	2 m 6.6'	Approx. 160 g 5.64 oz
		<b>OP-88087</b>		5 m 16.4'	Approx. 340 g 11.99 oz
		<b>OP-88088</b>		10 m 32.8'	Approx. 660 g 23.28 oz

Description	Appearance	Model	Usage	Weight
Protection cover		<b>FD-RP1</b>	Prevent damage to the main unit or unintended settings changes Material : SUS304, Polycarbonate	Approx. 285 g 10.05 oz
Modular cable		<b>OP-26487</b>	Send recorded data stored in FD-R to a computer	Approx. 72 g 2.54 oz
RS-232C conversion adapter (9-pin)		<b>OP-26401</b>		Approx. 25 g 0.88 oz

\* Recorded data cannot be transferred from the FD-R unit when a sub unit is used.

# OPERATING PRINCIPLE AND TECHNOLOGY

## Delta TOF

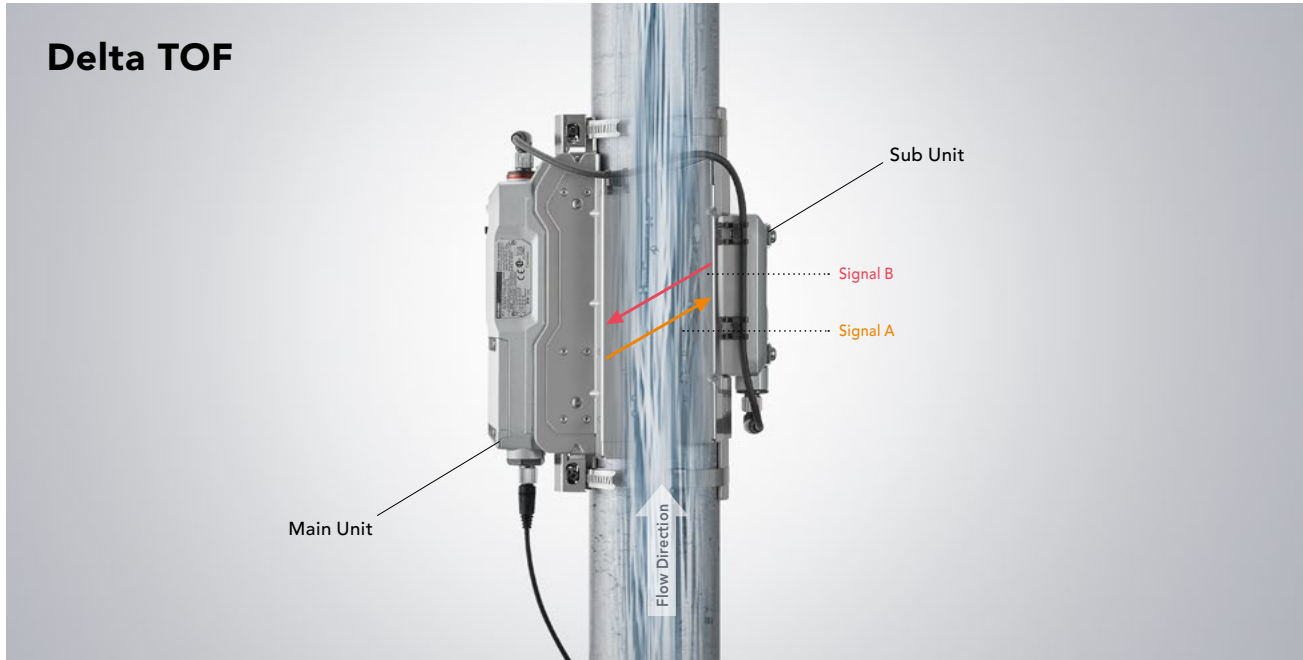

Conventional ultrasonic flow meters measure flow by monitoring the time it takes for an ultrasonic pulse to travel from a transmitting element to a receiving element. As the flow rate increases, the signal is accelerated and the transmission time decreases. This transmission time can then be directly correlated to the instantaneous flow rate. The FD-R Series improves upon this method of detection by simultaneously monitoring two signals (one moving in the direction of flow and one moving against the direction of flow). By doing this, the readings remain consistent and stable regardless of external factors such as clogging or temperature changes.

### Basic Principle

The duration of the pulse is easily influenced by external factors.

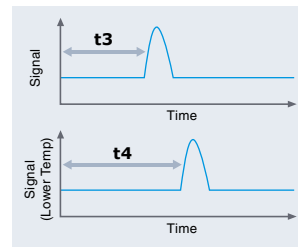

### Delta TOF

External factors do not affect detection as the time DIFFERENCE between signals A and B remains the same.

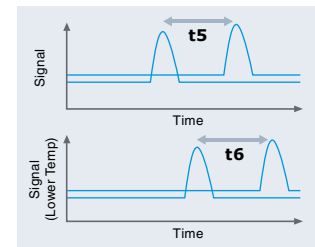

## Optimal Frequency Selection

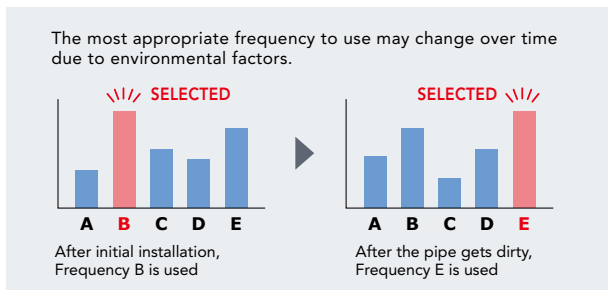

Unlike conventional flow meters, which typically use only one frequency for their ultrasonic signal, the FD-R Series continuously tests various frequencies to determine the ideal fit in every situation. By selecting the signal that travels through the pipe, liquid, and potential build-up with the least amount of loss, the FD-R Series is able to ensure proper flow monitoring.

## Automatic Build-Up Resistance

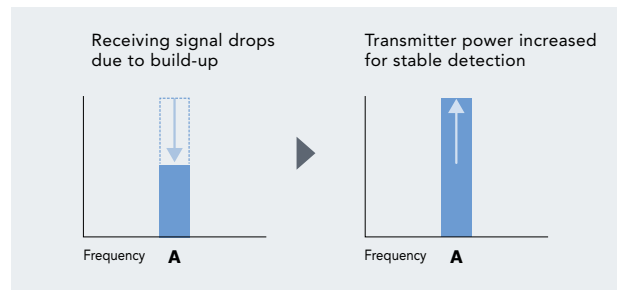

The stable transmission of the ultrasonic signal is imperative for consistently stable detection. Build up or rust on the inside of a pipe can become problematic over time for conventional flow sensors. By utilizing the Automatic Build-Up Resistance Function, the FD-R automatically adjusts its power to compensate for this build-up and provide lasting stable detection.

SPECIFICATIONS



Model	FD-R50		FD-R80		FD-R125		FD-R200		
Supported pipe diameter	DN (Diameter Nominal)	40 A	50 A	65 A	80 A	100 A	125 A	150 A	200 A
	NPS (Nominal Pipe Size)	1 1/2"	2"	2 1/2"	3"	4"	5"	6"	8"
	Outer diameter of pipe (mm)	ø44 to ø55 1.73" to 2.17"	ø55 to ø64 2.17" to 2.52"	ø64 to ø83 2.52" to 3.27"	ø83 to ø100 3.27" to 3.94"	ø100 to ø127 3.94" to 5.00"	ø127 to ø152 5.00" to 5.98"	ø152 to ø191 5.98" to 7.52"	ø191 to ø220 7.52" to 8.66"
Supported pipe materials	Metal/resin <sup>*1</sup>								
Supported fluids	Various liquids (i.e. water, oils, chemicals) <sup>*1</sup>								
Fluid temperature	-20 to +120°C -4.0 to +248 °F (no freezing on the pipe surface) <sup>*2</sup>								
Rated flow velocity range	5.0 m/s								
	Flow rate range (Typical)	(400 L/min 100 gal/min 24 m <sup>3</sup> /h)	(600 L/min 150 gal/min 36 m <sup>3</sup> /h)	(1000 L/min 260 gal/min 60 m <sup>3</sup> /h)	(1500 L/min 390 gal/min 90 m <sup>3</sup> /h)	(2500 L/min 660 gal/min 150 m <sup>3</sup> /h)	(3700 L/min 990 gal/min 220 m <sup>3</sup> /h)	(5500 L/min 1400 gal/min 330 m <sup>3</sup> /h)	(9500 L/min 2500 gal/min 570 m <sup>3</sup> /h)
Zero cut (default) <sup>*3</sup>	0.3 m/s								
	Flow rate (Typical)	(36 L/min 9 gal/min 2.4 m <sup>3</sup> /h)	(90 L/min 24 gal/min 5.4 m <sup>3</sup> /h)	(220 L/min 60 gal/min 12 m <sup>3</sup> /h)	(570 L/min 150 gal/min 36 m <sup>3</sup> /h)				
Display method	Dual row, 5-digit display with white, 14-segment LED; Large status indicator; Output indicators; Stability indicator; Unit indicator								
Display update cycle	Approx. 3 Hz								
Display resolution	0.1 / 1 (L/min)		1 (L/min)						
Response time	0.5 s / 1.0 s / 2.5 s / 5.0 s / 10.0 s / 30.0 s / 60.0 s / 120.0 s / 200.0 s (variable)								
Measurement accuracy	Between 20 and 100% of F.S.				±2.0% of RD <sup>*4,5</sup>				
	Between 6 and 20% of F.S.				±0.4% of F.S. <sup>*4,5</sup>				
Zero point error	±0.5% of F.S. <sup>*4,6</sup>								
Hysteresis	Variable								
Flow units	L/min, m <sup>3</sup> /h, gal/min								
Integrated flow unit display	1/10/100/1000/10000 (L)								
Pipe temperature measurement accuracy (ambient operating temperature of 25°C 77°F) <sup>*4</sup>	±3°C ±5.4°F (liquid temperature of -20 to +50°C, -4 to +122°F) ±5°C ±9°F (liquid temperature of 50 to +120°C, 122 to 248°F)								
Wiring specifications	Power supply	DC power supply: M12 4-pin connector/AC power supply: M4 screw terminal block (selectable)							
	I/O	When using a DC power supply: M12 4-pin connector/when using an AC power supply: M3 screw terminal block							
I/O <sup>*7</sup> (selectable)	Control output (ch.1/ch.2)	Control output/Integrated pulse output/Error output/Temperature alarm, NPN/PNP setting switchable, open collector output 30 VDC or less, max. 100 mA/ch., residual voltage: 2.5 V or less							
	Analog output (ch.1/ch.2)	Flow rate analog output/Temperature analog output and 4-20 mA / 0-20 mA (selectable), load resistance: 500 Ω or less							
	External input (ch.2)	Integrated flow reset input/Flow rate zero input/Origin adjustment input (selectable), short-circuit current: 1.5 mA or less, input time: 20 ms or more							
Rating	Power supply voltage	20 to 30 VDC including 10% ripple (P-P), Class 2/100 to 240 VAC - 15% or + 10%(50/60 Hz)							
	Current consumption	When using a DC power supply: 200 mA or less (load current excluded), 400 mA or less (load current included) When using an AC power supply: 15 VA or less							
Protection circuit	Power supply reverse connection protection, Power supply surge protection, Short-circuit protection for each output, Surge protection for each output								
Environmental resistance	Enclosure rating	IP65/67(IEC60529), IP69K(ISO20653), Enclosure Type 4X(NEMA250)							
	Ambient temperature	-20 to +60°C -4.0 to 140 °F (no freezing) <sup>*2</sup>							
	Ambient humidity	5 to 90%RH (no condensation)							
	Vibration resistance	10 to 55 Hz, compound amplitude 1.5 mm 0.06", XYZ axes 2 hours for each axis							
	Shock resistance	100 m/s <sup>2</sup> ; 16 ms pulse, XYZ axes, 1000 times for each axis							
Material	Main unit	Body: aluminum die-casting + coating/PPS, display: reinforced glass, connectors: SUS304-equivalent							
	Unit rear	Rubber							
	Upper/lower bracket	SUS304							
Weight	Main unit	Approx. 1.0 kg							
	Upper/lower bracket (including sub unit)	Approx. 1.5 kg 3.31 lb	Approx. 2.0 kg 4.41 lb	Approx. 2.3 kg 5.07 lb					Approx. 2.5 kg 5.51 lb
Main unit size	218.5 mm × 66.9 mm × 70.7 mm 8.60" × 2.63" × 2.78"								

\*1 Liquid must allow for the passage of an ultrasonic pulse, as well as not contain large air pockets or excessive bubbles. Detection may be unstable due to the type and status of the pipes.  
 \*2 Perform derating depending on the ambient temperature and liquid temperature when using an AC power supply.  
 \*3 The zero cut flow rate can be changed in the settings.  
 \*4 This value is guaranteed by KEYENCE inspection facilities. Errors will be introduced by the type and status of the pipes, the type and temperature of the fluid, and the zero cut flow rate.  
 \*5 This is the value when considering linearity + span error + repeatability in a stable environment of 25°C 77°F.  
 \*6 It is possible to enhance the precision of zero point error by performing an origin adjustment.  
 \*7 IO-Link: Compatible with Specification v1.1 / COM2 (38.4 kbps) The setting file can be downloaded from the KEYENCE website (<http://www.keyence.com>). If using the unit in an environment where downloading the file is not accessible via Internet, contact your nearest KEYENCE office. IO-Link is either registered trademarks or trademarks of PROFIBUS Nutzerorganisation e.V. (PNO)

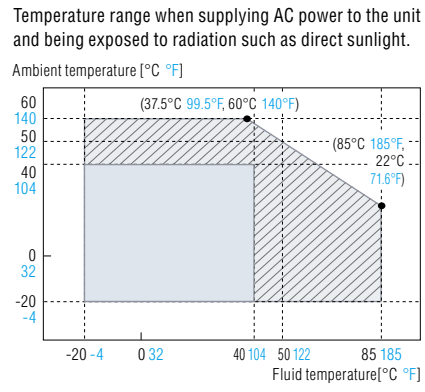
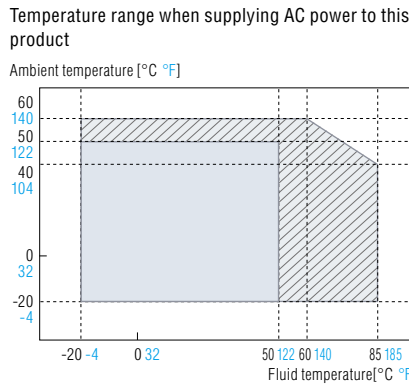
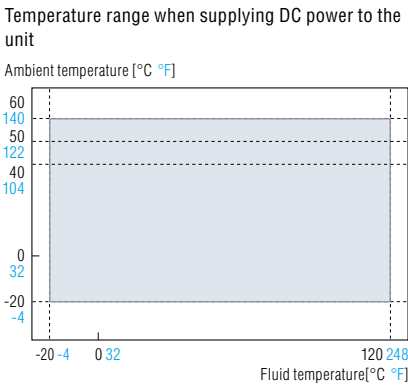

When using the FD-R Series in the temperature condition shown by oblique lines, use cables with heat resistance of 90°C 194°F or higher for the power cables and the I/O cables.

**Flow meter**

**FD-R50**

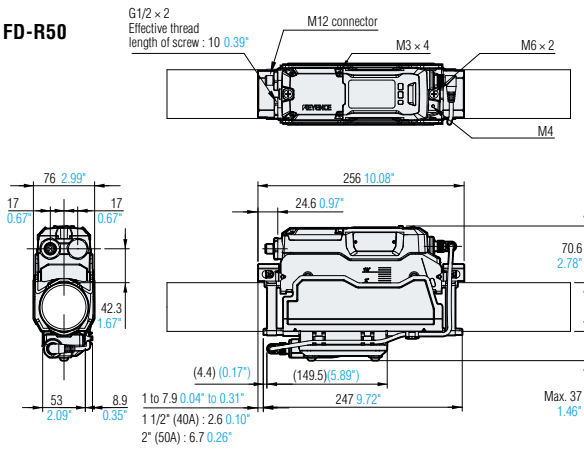

**FD-R80**

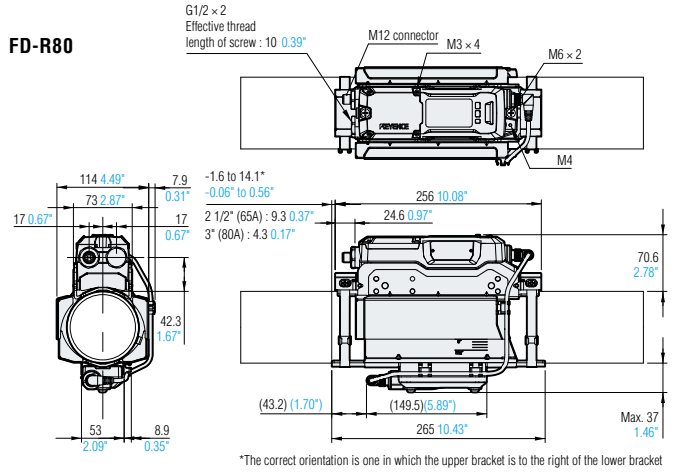

**FD-R125/FD-R200**

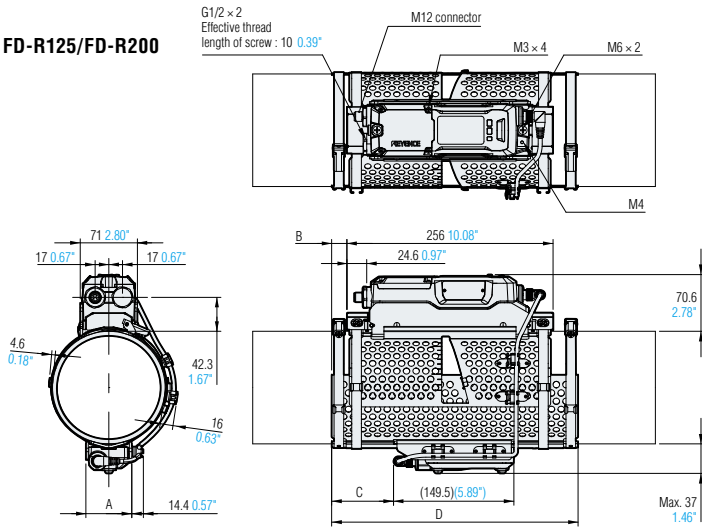

	FD-R125	FD-R200
A	57 2.24"	62 2.44"
B	14.1 to 34.6 0.56" to 1.36"	17.1 to 42.9 0.67" to 1.69"
	4" (100 A) : 29 1.14"	6" (150 A) : 37.6 1.48"
	5" (125 A) : 19 0.75"	8" (200 A) : 18.5 0.73"
C	(76.9) (3.03")	(104.3) (4.11")
D	306 12.05"	315 12.40"

**M12 power supply cable**

**Indoor use (standard) (OP-75721/85502)**

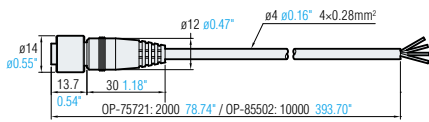

**Indoor use (oil resistant) / Outdoor use (OP-87636/87637/88196)**

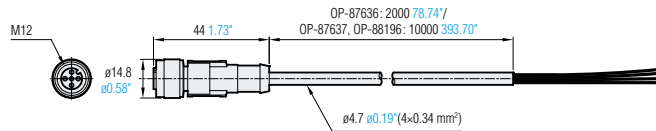

Pin layout

No.	Color
①	Brown
②	White
③	Blue
④	Black

When the M12 power supply cable is attached

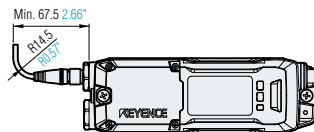

## Cable gland

### OP-88199

When the cable glands are attached

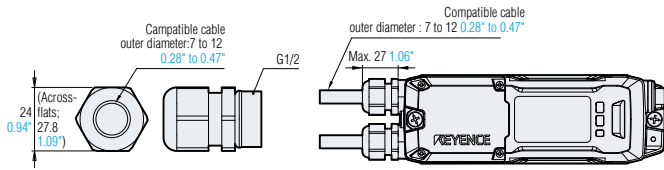

## Thread conversion coupling

### OP-88200/88201

When the thread conversion couplings are attached

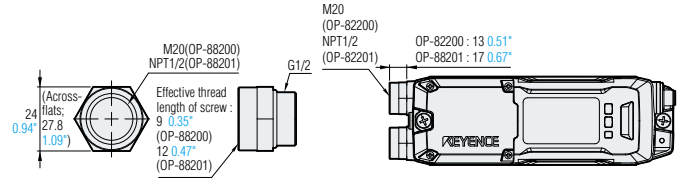

## Protection cover

### FD-RP1

When the protection cover is attached

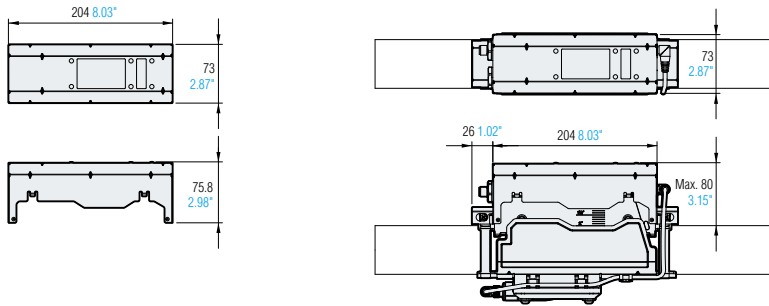

## Display Unit

### FI-1000

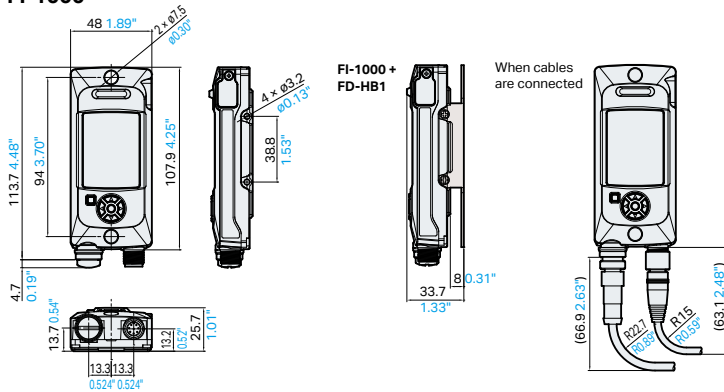

## FI-1000 power supply cables

### M12 power supply cable 8-core FD-HCB2/HCB10

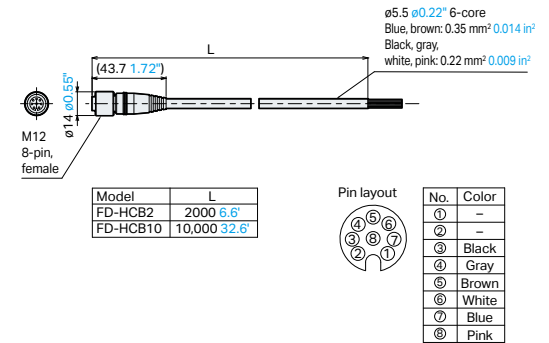

## FD-R Series connection cable

### OP-88671

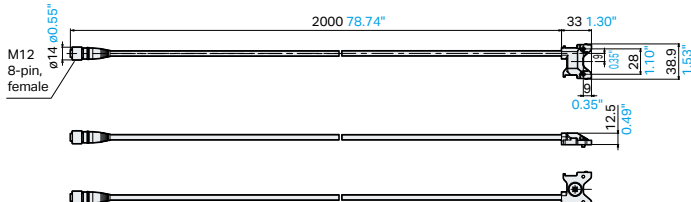

## FI-1000 display unit protection cover

### FD-HP1

Polysulfone

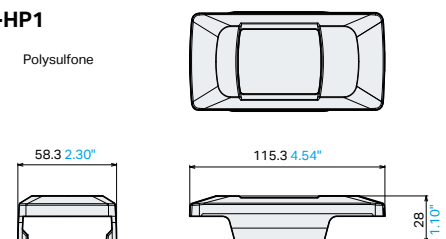

# WIRING

## When supplying DC power to the unit

The wiring varies depending on the selected functions.

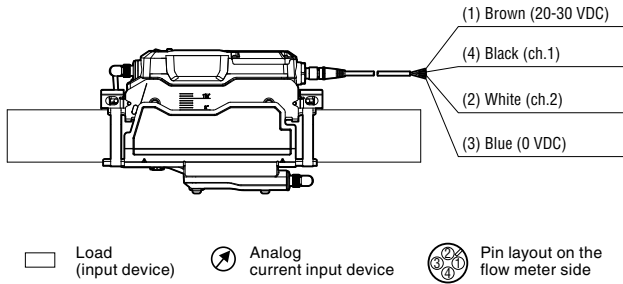

### When ch.1: OUT, ch.2: OFF or ch.1: OUT, ch.2: OUT are selected

#### NPN

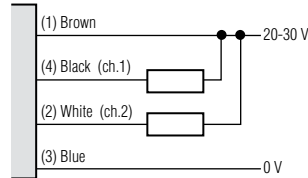

#### PNP

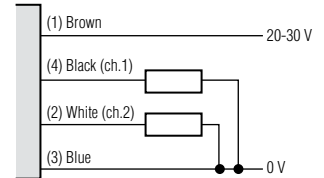

When you select ch.1: OUT, ch.2: OFF, independently insulate the white wire (2).

### When ch.1: OUT, ch.2: Analog are selected

#### NPN

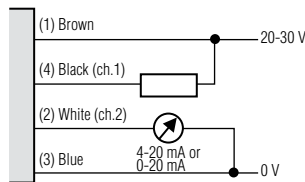

#### PNP

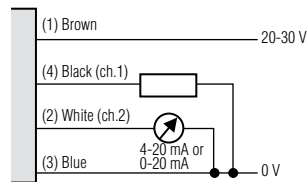

### When ch.1: OUT, ch.2: input are selected

#### NPN

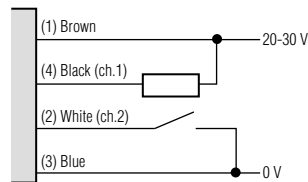

#### PNP

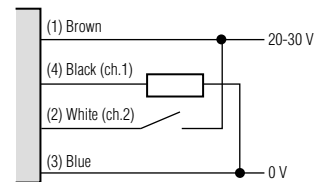

### When ch.1: Analog, ch.2: OFF or ch.1: Analog, ch.2: Analog are selected

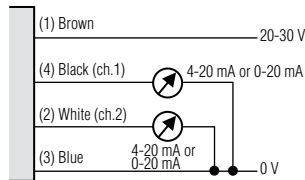

When you select ch.1: Analog, ch.2: OFF, independently insulate the white wire (2).

### When ch.1: Analog, ch.2: Input are selected

#### NPN

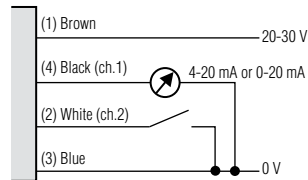

#### PNP

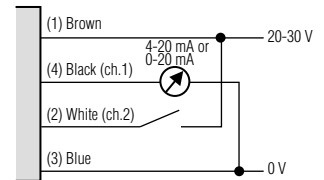

## When supplying AC power to the unit

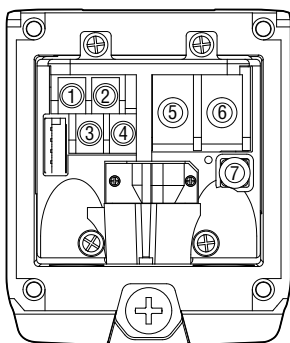

Terminal block number	Terminal signal	Purpose
(1)	ch.1	ch.1
(2)	ch.2 <sup>*1</sup>	ch.2
(3)	COM+ <sup>*2</sup>	Common (+)
(4)	COM-	Common (-)
(5)	L	Power supply
(6)	N	
(7)	PE <sup>*3</sup>	Protective grounding terminal

\*1 The ch.2 core wire is not required when the ch.2 function is not being used.

\*2 The COM+ core wire is not required, when the analog outputs are used only.

\*3 PE is only required when the terminal block of the main unit is used to perform grounding.

\*4 The I/O terminal block (parts [1] to [4]) and the AC terminal block (parts [5] and [6]) are insulated.

**Standalone Display Unit (FI-1000)**

Model	<b>FI-1000</b>	
Display	QVGA 2.0 model: color LCD, status indicator light	
Display update cycle	Approx. 10 times/second	
Heat calculation function*1	Unit	MJ/h, kW, kBTU/h, GJ/h, MW, MBTU/h
	Display resolution	Instantaneous value (MJ/h): 0.01/0.1/1 (default value 0.1); Integrated value (MJ): 0.01/0.1/1 (default value 0.1)
	Pulse output increments (MJ)	0.02-999.99
Data accumulation	Accumulation period	Approx. 1 year
	Data reading	USB2.0
Power supply I/O connector	M12 8-pin connector (male)	
I/O (switchable)	Output (Ch1/2/3/4)	NPN/PNP setting switching, open collector output 30 VDC or less, max. 100 mA/ch or less, residual voltage 2.5 V or less
	Analog output (Ch1/2)	4-20 mA/0-20 mA (switchable), load resistance 500 Ω or less
	External input (Ch2/3)	Short circuit current: 1.5 mA or less; input time: 20 ms or more
Power supply	Power voltage	20-30 VDC, ripple (P-P) 10% included, Class 2/LPS
	Current consumption	55 mA or less (display unit standalone, excluding load current)*2
Protection circuit	Protection against reverse power connection, power supply surges, output short circuits, and output surges	
Network compatibility	IO-Link*3	
Environmental resistance	Enclosure rating	IP65/IP67 (IEC60529)*4
	Operating ambient temperature	-20°C to +50°C <b>-4°F to +122°F</b> (no freezing)
	Operating ambient humidity	35-85% RH (no condensation)
	Vibration resistance	10-500 Hz; Power spectral density: 0.816 G <sup>2</sup> /Hz; X, Y and Z directions
Shock resistance	100 m/s <sup>2</sup> (approx. 10 G), 16 ms pulses, 1000 times each for X, Y and Z directions	
Material	Body: PPS / PET / POM; Display window: PAR	
Weight	Approx. 120 g <b>4.23 oz</b>	

\*1 Available when the separately sold flow meter FD-R Series and two temperature sensors are connected.  
 \*2 455 mA or less including load. When connecting devices such as temperature sensors, please add on the current consumption of each sensor (to a maximum of 830 mA or less).  
 \*3 Supports IO-Link specification v.1.1/COM2 (38.4 kbps). Setting files can be downloaded from the KEYENCE website (www.keyence.com). IO-Link is a trademark or registered trademark of PROFIBUS Nutzerorganisation e.V. (PNO).  
 \*4 When a USB connection is in use, IP65/67 compliance is impaired.

**When using FI-1000**

The FI-1000 Series allows users to allocate control outputs, external inputs, and analog outputs to 4 different I/O channels (Ch1 to Ch4) according to the settings.

Wire color	Function
Brown	Power supply + 20-30 V
Blue	GND
Black (Ch1)*1	Control output or analog output (selectable)
White (Ch2)	Control output, analog output, or external input (selectable)*2
Gray (Ch3)	Control output or external input (selectable)*2
Pink (Ch4)	Control output (fixed)

\*1 IO-Link wire during IO-Link communication.  
 \*2 Two external input wires are required for the bank input function, set Ch2 and Ch3 to external input to use this function.

**(1) Wiring of channel to which control output has been selected**

**When NPN is selected**

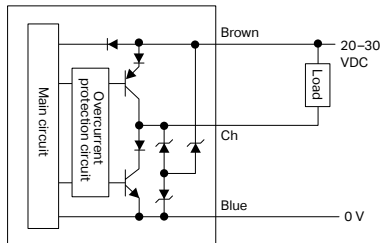

**When PNP is selected**

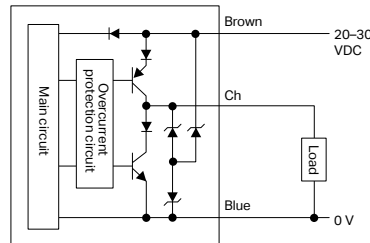

**(2) Wiring of channel to which external input has been selected**

**When NPN is selected**

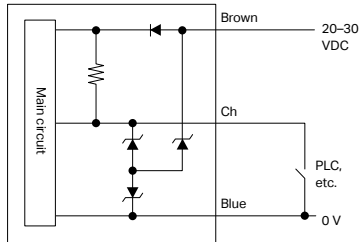

**When PNP is selected**

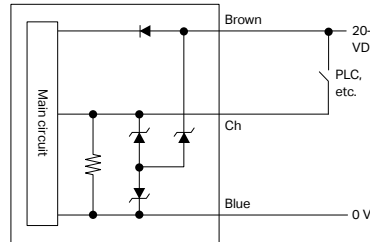

**(3) Wiring of channel to which analog output has been selected**

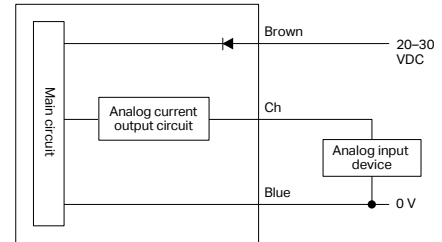

\*Can be switched to 4-20 mA or 0-20 mA using the settings

Clamp-On Flow Sensor FD-H Series

# The Next Evolution in CLAMP-ON



## Utilize Anywhere

### Any Pipe

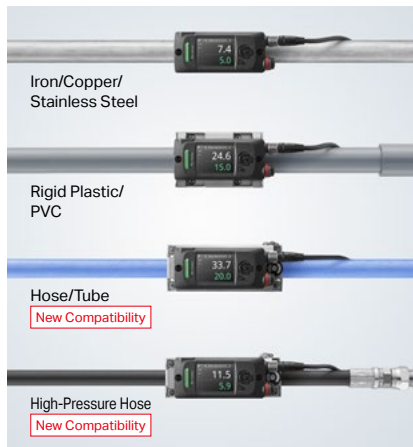

### Any Liquid

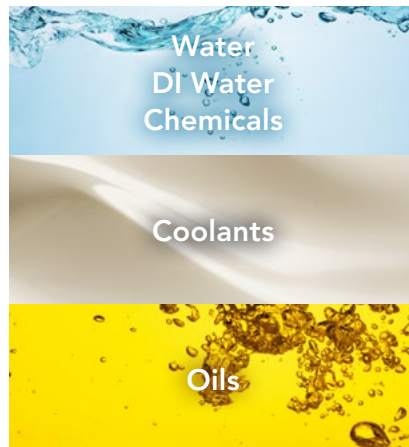

### Any Condition

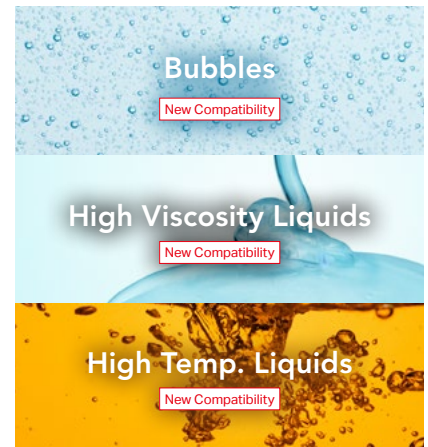

## Lineup

### Standard Type

Model	Rated flow	Supported pipe sizes	Pipe outer diameter
FD-H10	20 L/min 5.3 gal/min	1/4" (8 A)	ø13-16 ø0.51"-0.63"
	30 L/min 7.9 gal/min	3/8" (10 A)	ø16-18 ø0.63"-0.71"
FD-H20	60 L/min 15.9 gal/min	1/2" (15 A)	ø18-23 ø0.71"-0.91"
	100 L/min 26.4 gal/min	3/4" (20 A)	ø23-28 ø0.91"-1.10"
FD-H32	200 L/min 52.8 gal/min	1" (25 A)	ø28-37 ø1.10"-1.46"
	300 L/min 79.3 gal/min	1 1/4" (32 A)	ø37-44 ø1.46"-1.73"

- Rigid piping
- Built-in temperature sensor
- Compatible with fluids with bubbles

**IO-Link**



140°C 284°F or lower

Between  
140-180°C  
284-356°F



**Ultra-high-temperature couplant** **Required**

If the fluid temperature exceeds 140°C 284°F, it is necessary to change the couplant and separate the display unit from the sensor.

**FD-HK1:** for FD-H10K  
**FD-HK2:** for FD-H20K  
**FD-HK3:** for FD-H32K

### Power supply cables **Required**

Dedicated power supply cable

Appearance	Model	Overview
	<b>FD-HCB2</b>	M12 power supply cable 6-core cable PVC 2 m 6.6'
	<b>FD-HCB10</b>	M12 power supply cable 6-core cable PVC 10 m 32.8'

### For IO-Link communication

Can be converted to 4 pins using the below.

Appearance	Model	Overview
	<b>FD-HCC2</b>	M12 power supply cable 8-pin female to 4-pin male PVC 2 m 6.6'
	<b>FD-HCC10</b>	M12 power supply cable 8-pin female to 4-pin male PVC 10 m 32.8'
	<b>FD-HCC0</b>	8-pin female to 4-pin male adapter

### High-Temperature Type

Model	Rated flow	Supported pipe sizes	Pipe outer diameter
FD-H10K	20 L/min 5.3 gal/min	1/4" (8 A)	ø13-16 ø0.51"-0.63"
	30 L/min 7.9 gal/min	3/8" (10 A)	ø16-18 ø0.63"-0.71"
FD-H20K	60 L/min 15.9 gal/min	1/2" (15 A)	ø18-23 ø0.71"-0.91"
	100 L/min 26.4 gal/min	3/4" (20 A)	ø23-28 ø0.91"-1.10"
FD-H32K	200 L/min 52.8 gal/min	1" (25 A)	ø28-37 ø1.10"-1.46"
	300 L/min 79.3 gal/min	1 1/4" (32 A)	ø37-44 ø1.46"-1.73"

- Rigid piping
- Compatible with fluids with bubbles

**IO-Link**



### Hose Type

Model	Rated flow	Pipe outer diameter
FD-H22F	60 L/min 15.9 gal/min	ø13-22.9 ø0.51"-0.90"
FD-H32F	200 L/min 52.8 gal/min	ø23-32.9 ø0.91"-1.295"
FD-H47F	300 L/min 79.3 gal/min	ø33-47.9 ø1.299"-1.886"
FD-H63F	500 L/min 132.1 gal/min	ø48-63 ø1.89"-2.48"

- Hoses/Tubes
- High-viscosity liquid compatible

**IO-Link**



**Stabilization bracket**

**Optional**

Can be used to secure hose models to walls, etc. Can be used with any of the four different hose models.

**FD-HFB1**

## Accessories (Display Unit Related)

### Heavy Duty Protection Cover

Standard models only

Heavy duty protection cover  
**FD-HP2**



Heavy duty power supply cable  
**FD-HCB10G**  
M12 6-core cable  
PVC 10 m 32.8'



**Display unit protection cover**

**Optional**  
**FD-HP1**

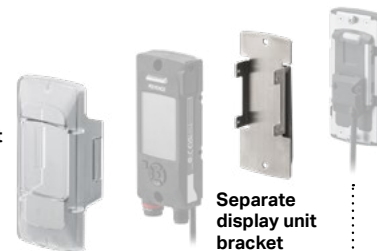

**Separate display unit bracket**

**Optional** **FD-HB1**

\*Can also be used with the FI-1000.

### Connection cable when separating the display **Optional**

A dedicated cable for when using the display unit separated from the sensor.

Appearance	Model	Overview
	<b>FD-HCS2</b>	Display unit separation connection cable PVC 2 m 6.6'

Can be extended an additional 18 m 59.1' (for a total of 20 m 65.6') using these M12-M12 connector cables.

	<b>OP-85503</b>	2 m 6.6' PVC
	<b>OP-85504</b>	5 m 16.4' PVC
	<b>OP-88075</b>	2 m 6.6' PUR
	<b>OP-88076</b>	5 m 16.4' PUR

- To output historical data to a PC: USB cable OP-51580 (2 m 6.6') or OP-86941 (5 m 16.4') can be used. Historical data that can be output includes: 1) Instantaneous data and stability for every 10 seconds over the past 7 days, 2) Instantaneous data and stability for every 10 minutes over the past year, 3) Accumulated flow data for every hour over the past year, 4) Accumulated heat transfer data for every hour over the past year, and 5) Up to 100 events.

Digital Refractometer FI-C Series

**Probe type**

Digital Refractometer  
Probe Type  
FI-C20D **NEW**



Measuring Accuracy  
Brix  $\pm 0.2\%$

Built-in temperature sensor

**In-Line type**

Digital Refractometer  
In-Line Type  
FI-C40F **NEW**

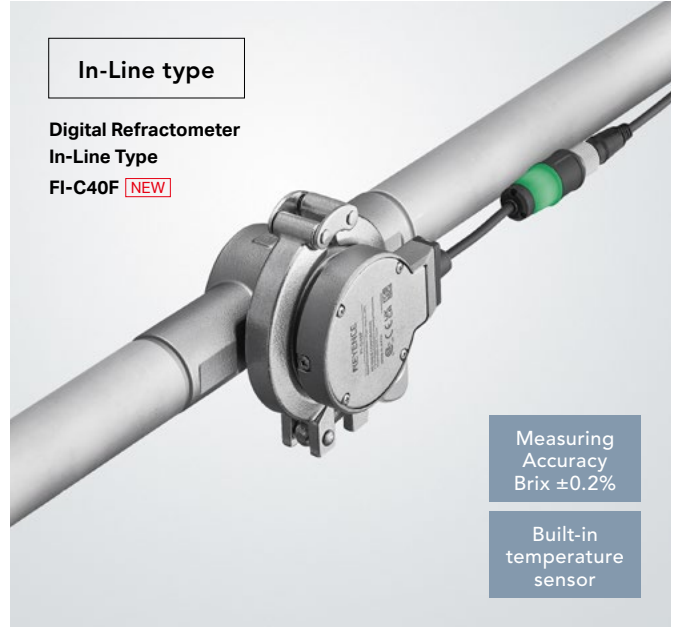

Measuring Accuracy  
Brix  $\pm 0.2\%$

Built-in temperature sensor

**Stable & Reliable Detection**

Stably measure the refractivity (Brix%) of the liquid regardless of bubbles or build-up.

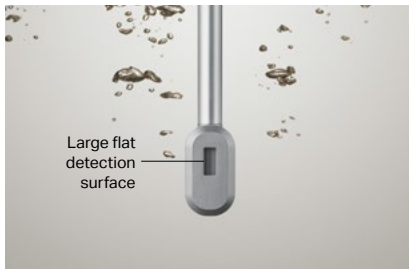

**Tool-Free Maintenance**

No tools are required to remove and clean the units, greatly minimizing downtime.

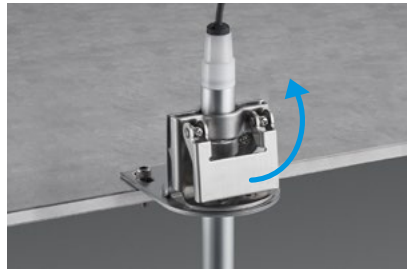

**Large Status Indicator**

Understand the current situation at a glance, including recognizing potential issues.

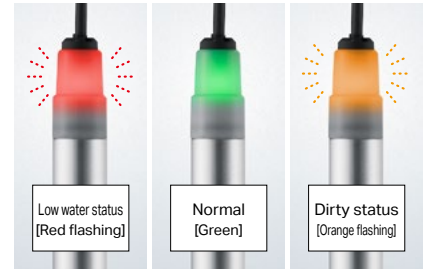

**Lineup**



**Probe Type**

Cable length  
2 m 6.6'

Probe Length  
(bottom of indicator to center of detection element):  
331.5 mm 13.05"

Model	Installation
<b>FI-C20D</b>	Probe type

**Options**

Appearance	Model	Overview
	<b>FI-CDB1</b>	Dedicated bracket for probe type
	<b>FI-CD1</b>	Extension pipe* 0.4 m 1.3'
	<b>FI-CD2</b>	Extension pipe* 0.8 m 2.6'





\*Only one extension pipe can be used per setup

**In-Line Type**

Cable length  
50 mm 1.97"

Model	Installation
<b>FI-C40F</b>	2S ferrule attached to dedicated pipe attachment

**Options**

Appearance	Model	Overview
	<b>FI-CF1</b>	Pipe attachment Rc3/4
	<b>FI-CF3</b>	Pipe attachment NPT3/4
	<b>FI-CF2</b>	Pipe attachment Rc1-1/2
	<b>FI-CF4</b>	Pipe attachment NPT1-1/2

**Display unit**

FI-1000 Display Unit or FD-H Series is necessary

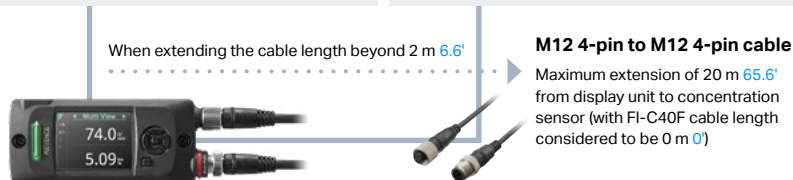

Model	Overview
<b>OP-85503</b>	2 m 6.6' PVC
<b>OP-85504</b>	5 m 16.4' PVC
<b>OP-88075</b>	2 m 6.6' PUR
<b>OP-88076</b>	5 m 16.4' PUR

## Temperature Sensor FI-T Series



**Small pipes**  
1/8" to 1/2"

**Clamp-On Temperature Sensor**  
**FI-T8/T15** **NEW**  
Attach to the pipe with two screws



**Medium/large pipes**  
3/4" to 8"

**Clamp-On Temperature Sensor**  
**FI-T25/T50/T100/T200** **NEW**  
Attach to the pipe with metallic bands

### Easy Installation

No pipe modifications necessary. The unit clamps onto the pipe in seconds.



### Dedicated Display Amplifier

The easy to read OLED display allows users to understand the current situation quickly.



### Heat Transfer Monitoring

Connect multiple units to a flow sensor to determine heat transfer in to or out of a system.

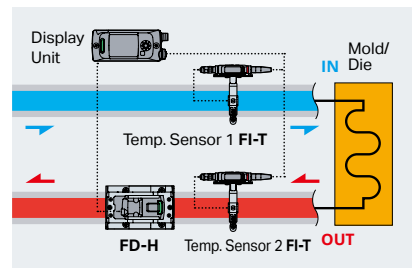

### Lineup

Model	Supported pipe sizes	Pipe outer diameter
FI-T8	1/8", 1/4" (6 A/8 A)	ø8-14 ø0.31"-0.55"
FI-T15	3/8", 1/2" (10 A/15 A)	ø14-22 ø0.55"-0.87"
FI-T25	3/4", 1" (20 A/25 A)	ø22-38 ø0.87"-1.50"
FI-T50	1 1/4", 1 1/2", 2" (32 A/40 A/50 A)	ø38-70 ø1.50"-2.76"
FI-T100	2 1/2", 3", 3 1/2", 4" (65 A/80 A/90 A/100 A)	ø70-126 ø2.76"-4.96"
FI-T200	5", 6", 8" (125 A/150 A/200 A)	ø126-220 ø4.96"-8.66"

\*If using the FI-T temperature sensor on its own, use a 4-pin M8 connector cable. (Examples: OP-87625 (PVC, 2 m 6.6'), OP-87626 (PVC, 10 m 32.8'), OP-87628 (PUR, 2 m 6.6'), OP-87629 (PUR, 10 m 32.8')

#### Display amplifier

Cable length:  
Approx. 250 mm 9.84"

#### Head

#### M8-M8 extension cable

**Optional**

Maximum extension of 20 m 65.6' from display amplifier to head

OP-88673 PVC 2 m 6.6'  
OP-88672 PVC 10 m 32.8'

#### Display unit

Can be connected to FI-1000 or FD-H Series for complete process solution.

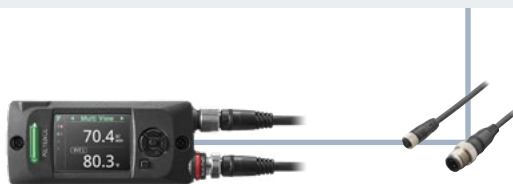

#### M8 4-pin to M12 4-pin cable

Maximum extension of 20 m 65.6' from the display unit to the temperature sensor display amplifier

Model	Overview
OP-88456	2 m 6.6' PVC
OP-88457	5 m 16.4' PVC
OP-88071	2 m 6.6' PUR
OP-88072	5 m 16.4' PUR



# Trouble-Free Level Sensing

## FL Series - Sensing Guide Pulse Level Sensor

Completely Eliminate **FALSE TRIPS** Caused By:

<b>Foam</b>	<b>Build-Up</b>	<b>Rust</b>
-------------	-----------------	-------------

### Consistently Stable Level Detection

The FL Series utilizes the innovative sensing guide pulse method of level detection. This style of level detection works by transmitting an electrical pulse down a probe and measuring the amount of time it takes to reflect off the liquid surface and back to sensor.

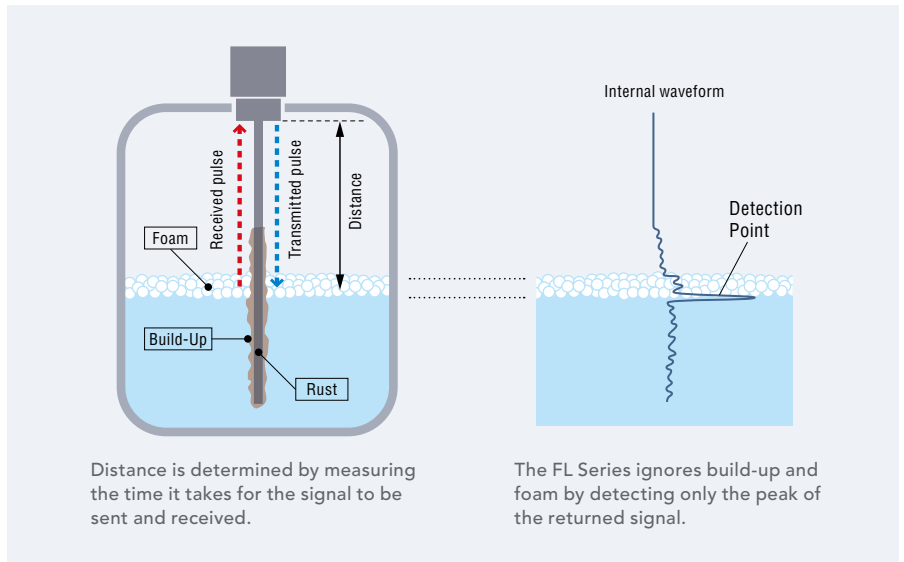

### Compatible with Various Applications

Fluid Compatibility		Tank Size Compatibility	Application Compatibility
Water	Oil	 Probe Length <b>0.2 to 2 m</b> <b>0.6' to 6.6'</b>	4 Independent Outputs
Chemicals	Viscous Liquids		4 to 20 mA Analog Output
			Stability and Alarm Outputs

CONTACT YOUR NEAREST OFFICE FOR RELEASE STATUS

#### KEYENCE CORPORATION OF AMERICA

500 Park Boulevard, Suite 200, Itasca, IL 60143, U.S.A.

#### KEYENCE CANADA INC.

6775 Financial Drive, Suite 202, Mississauga, ON L5N 0A4, Canada

#### KEYENCE MÉXICO S.A. DE C.V.

Av. Paseo de la Reforma 243, P11, Col. Cuauhtémoc, C.P. 06500, Del. Cuauhtémoc, Ciudad de México, México

☎ +1-201-930-0100 ✉ keyence@keyence.com

☎ +1-905-366-7655 ✉ keyencecanada@keyence.com

☎ +52-55-8850-0100 ✉ keyencemexico@keyence.com

**CALL TOLL FREE**  
 1 - 8 8 8 - 5 3 9 - 3 6 2 3  
**1-888-KEYENCE**  
 TO CONTACT YOUR LOCAL OFFICE

The information in this publication is based on KEYENCE's internal research/evaluation at the time of release and is subject to change without notice. Company and product names mentioned in this catalog are either trademarks or registered trademarks of their respective companies. The specifications are expressed in metric units. The English units have been converted from the original metric units. Unauthorized reproduction of this catalog is strictly prohibited.  
 Copyright © 2023 KEYENCE CORPORATION. All rights reserved.